

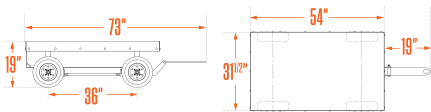

**T-20**

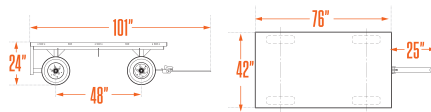

**T-20 HD**



**T-25**

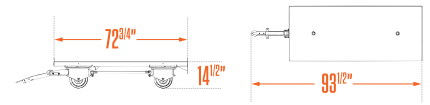

# WE'RE ALWAYS PULLING FOR YOU.

Save money, time and effort by exploiting the full potential of your Motrec tow tractor, burden carrier or stock chaser. Our tracking trailers are a simple and economical way to get more done in less time. With their tight turning radius and heavy-duty construction, our industrial trailers are strong and sturdy, but also highly maneuverable. These indispensable work tools are built specifically for Motrec electric vehicles, and can be easily customized for specific jobs if needed.

## SPECIFICATIONS

	T-20	T-20 HD	T-25
<b>LOAD CAPACITY</b>	750 lbs	2,000 lbs (upgradable up to 6,000 lbs)	2,500 lbs (upgradable up to 6,000 lbs)
<b>DECK DIMENSIONS</b>	31.5" x 54"	42" x 76"	30" x 72" (upgradable up to 54" x 144")
<b>WHEELS</b>	410 x 6, LRB sawtooth wheels	480 x 8, LRC Tires	10" solid wheels
<b>STEERING</b>	4-wheel tracking steering	Turning front axle and fixed rear axle	4-wheel tracking steering
<b>SUSPENSION</b>	Rigid axles	Rigid axles	Rigid axles
<b>SHELVES</b>	Included with triple deck version	Optional 2 additional shelves	Optional 1 or 2 additional adjustable shelves
<b>AVAILABLE OPTIONS</b>			
<b>TIRES &amp; WHEELS</b>	Flat prevention tire treatment	✓	✓
	5.7 x 8 LRD tires		✓
	Solid soft rubber wheels		✓
<b>STEERING</b>	4-wheel tracking steering	✓	✓
<b>HITCH</b>	Clevis hitch with safety spring	✓	✓
	Pintle hitch	✓	✓
	Automatic coupling hitch	✓	✓
<b>SHELVES</b>	Add 2 shelves, 16" H includes 2" lip, 100 lbs capacity	✓	✓
<b>OTHER OPTIONS</b>	Fully customizable	✓	✓
	Stake sides, front and rear, 14"H	✓	✓
	44" x 96" deck		✓

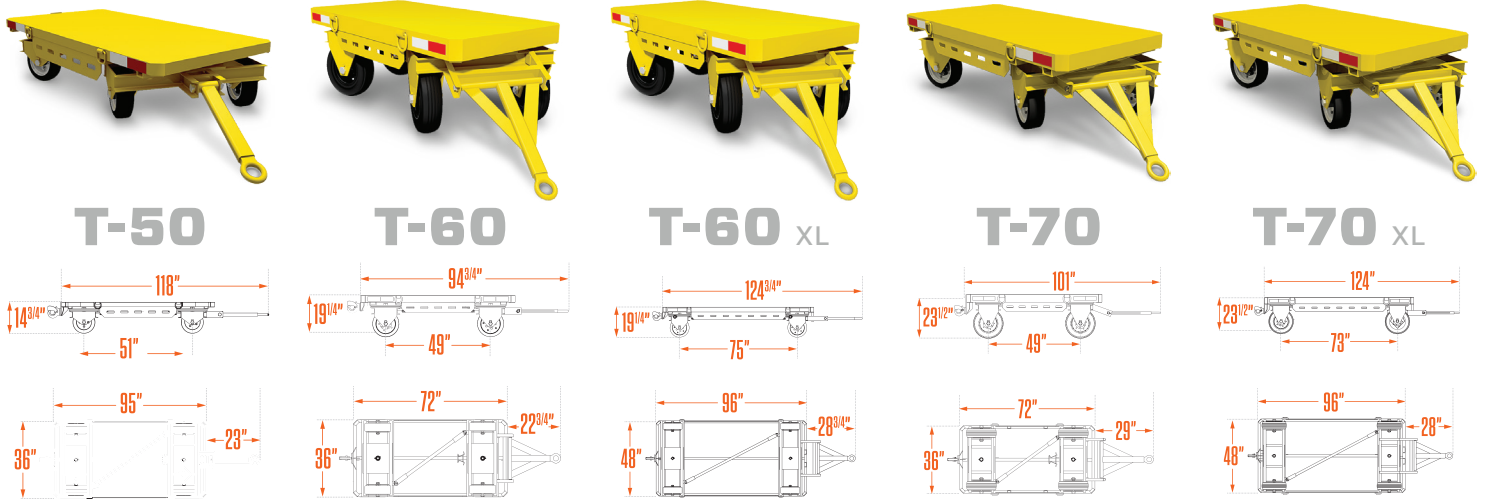

# BUILT FOR YEARS OF HEAVY-DUTY WORK.

Ruggedly built for use in trains, each trailer features a forged steel towing loop and solid pneumatic wheels, perfect for heavy duty towing applications. The Four-Wheel steering assures minimum floor space required for turning entire train, a significant cost advantage in a larger warehouse or distribution center. The steel deck accommodates virtually any kind of load and is forgiving of most loading and unloading indiscretions. Each trailer is equipped with mitered corners and indicative of premium design which allows for tight trailering turns without corner contact. Pintle hitch comes standard.

## SPECIFICATIONS

	T-50	T-60	T-60 XL	T-70	T-70 XL
<b>LOAD CAPACITY</b>	2,000 lbs	4,000 lbs	4,000 lbs	9,000 lbs	9,000 lbs
<b>DECK DIMENSIONS</b>	36" x 72 12 gauge steel deck	36" x 72 12 gauge steel deck	48" x 96" 12 gauge steel deck	36" x 72 7 gauge steel deck	48" x 96" 7 gauge steel deck
<b>WHEELS</b>	10" x 4" Solid pneumatic tires	12" x 4" Solid pneumatic tires	12" x 4" Solid pneumatic tires	16" x 5" Solid pneumatic tires	16" x 5" Solid pneumatic tires
<b>4-WHEEL STEER</b>	✓	✓	✓	✓	✓
<b>PINTLE HITCH</b>	✓	✓	✓	✓	✓
<b>MAX TRAIN</b>	6	4	4	3	3
<b>AISLE WIDTH NAVIGATION</b>	101"	93"	116"	90"	111"



## UNBEATABLE VEHICLES BACKED BY UNBEATABLE WARRANTIES

5-Year limited warranty on all Motrec vehicles with AC technology, our MS-260 stock chaser and all Motrec trailers.

